

e-straight

STEEL QUALITY	EN 10025-2:2004 - S235JR, cold drawn NBN A 24-302 - BE 500 TS
MATERIAL THICKNESS	2 x 5 mm (13/64") upper steel plates Body 1,5 mm (1/16")
PROFILE LENGTH	2,60 m (+ 5 mm / - 10 mm) (8.53 ft +13/64" / - 25/64")
JOINT OPPENING	Optimal and recommended up to 15 mm (19/32"), load transfer possible up to 25 mm (1")
ANCHORAGE	Patented, specially 3D formed rebar \varnothing 6 mm (15/64") as continuous anchorage
VERSIONS	Natural steel / Galvanized
PALLET SIZE	Length 2,60 m (8.53 ft), Width 1,15 m (3.77 ft), height see table



Height a [mm] (inch)	Slab thickness [mm] (inch)	b [mm] (inch)	Weight [kg/m] (lbs/ft)	Weight [kg/pc.] (lbs/pc.)	Quantity [pcs./pal.]	Quantity [m/pal.] (ft/pal.)	Gross weight per pal. [kg] (lbs)	Pallet Height [m] (ft)
130 (5 1/8)	140 - 150 (5 33/64 - 5 29/32)	30 (1 3/16)	7,37 (4.95)	19,15 (42.22)	56	145,6 (477.69)	1150 (2535)	1,15 (3.77)
155 (6 7/64)	160 - 180 (6 19/64 - 7 3/32)	65 (2 9/16)	7,78 (5.23)	20,22 (44.58)	49	127,4 (417.98)	1070 (2360)	1,26 (4.13)
180 (7 3/32)	190 - 200 (7 31/64 - 7 7/8)	90 (3 35/64)	8,07 (5.43)	20,99 (46.28)	42	109,2 (358.27)	960 (2115)	1,20 (3.94)
205 (8 1/16)	210 - 230 (8 1/4 - 9 1/16)	115 (4 17/32)	8,37 (5.62)	21,76 (47.97)	35	91,0 (298.56)	840 (1850)	1,10 (3.61)

The e-straight joint is recommended for the use in light and medium loaded floors and for floor thickness' between 140 and 200 mm (5.5" - 8"). Other heights for floor thicknesses above 200 mm (8") are available on request and function of the corresponding design check.

ATTENTION: Straight joints do not withstand forklift traffic with hard wheels! The load transfer capacity of e-slide® is reduced when compared to Cosinus Slide® but is still considerably greater than discontinued plate- or doweled joints. For calculations, validations and optimal use of the joints for your respective projects, please contact your local dealer or send a request to info@hcjoints.be.

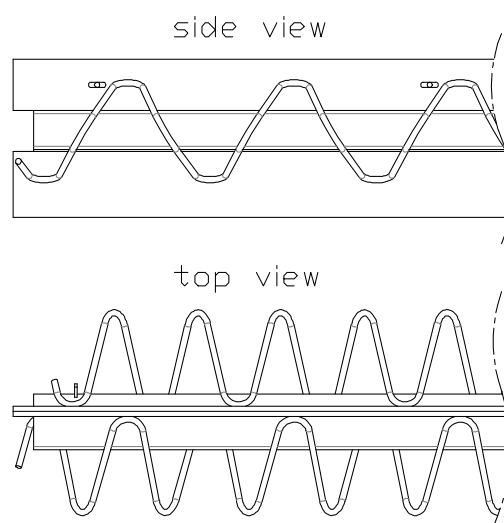
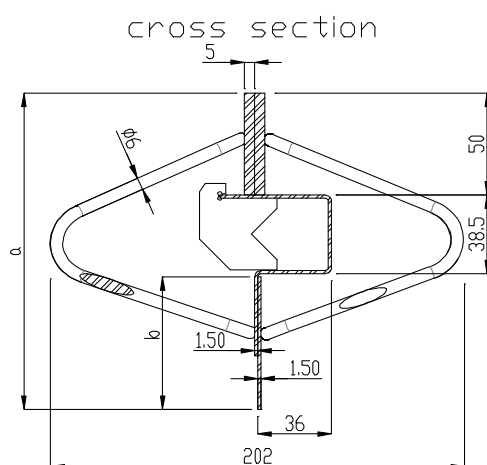

Document issued August 2021. Hengelhoef Concrete Joints nv. reserves the right to alter the products without notice.

©COPYRIGHT 2021 by Hengelhoef Concrete Joints nv.



HENGELHOEF
CONCRETE JOINTS

Hengelhoefstraat 158, Poort Genk 0420, B-3600 Genk
T. +32 (0)89 32 39 80 · F. +32 (0)89 32 39 88
E. info@hcjoints.be

www.hcjoints.be